



Process Engineering
Division

Niro

CIP

Cleaning-in-Place
of Spray
Drying Plants

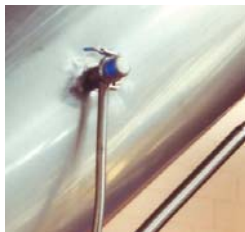

NIRO POWDER TECHNOLOGY

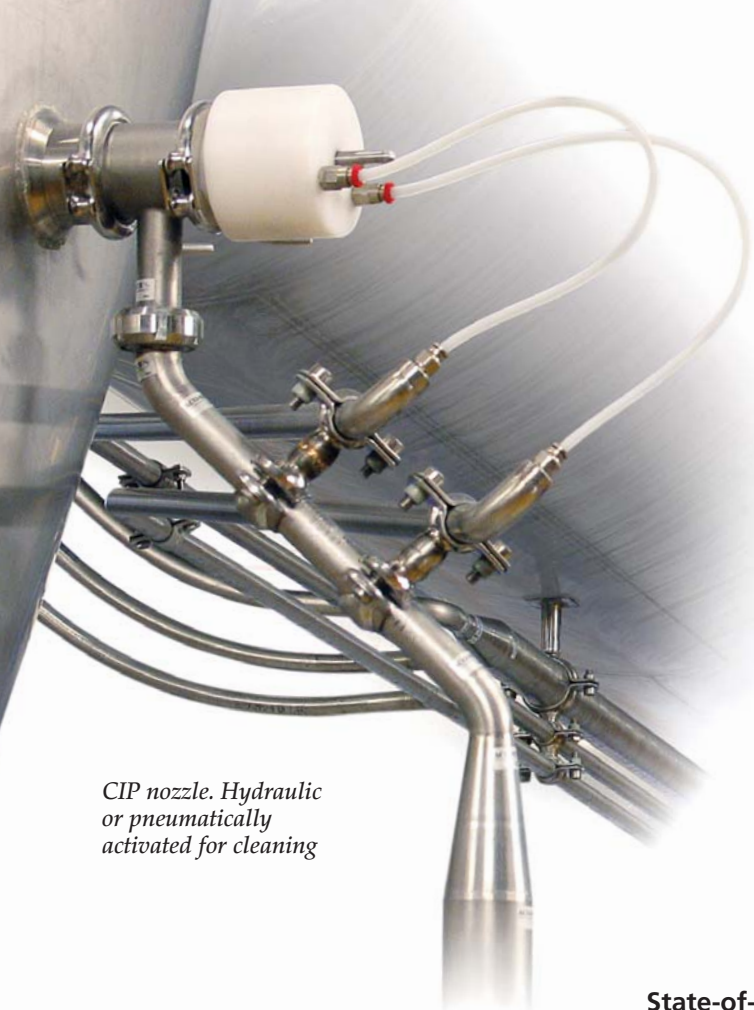

CIP nozzle. Hydraulic or pneumatically activated for cleaning



Chamber cone, integrated fluid bed and sieve with CIP nozzles

Design for Hygienic

performance

The hygienic aspects of producing dairy and food products are of extreme importance.

State-of-the-Art Cleaning Methods

To meet today's strict requirements, spray drying plants must satisfy the highest hygienic design standards to avoid product degradation and contamination during plant operation.

Wet and Dry Methods

Cleaning requirements for well designed liquid processing equipment are achieved by circulating cleaning solutions and water under well controlled conditions.

Cleaning requirements for the drying and powder handling equipment - the dry areas - can be met by either dry or wet methods, or a combination of both.

Dry methods involve the manual sweeping of surfaces in contact with the product, or air sweeping by allowing a high velocity air stream to pass over the surfaces in question.

Wet methods can involve either manual hosing of surfaces or more effectively by use of automated cleaning-in-place systems (CIP systems).

Niro has developed CIP systems to meet strict industrial requirements.



VIBRO-FLUIDIZER® and sieve with side-mounted CIP nozzles



High pressure atomizer nozzles ready for CIP cleaning. All nozzles lances and nozzle heads are placed in a special stand for cleaning



Spray drying chamber in CIP mode. Atomizer nozzles removed from atomization zone. A CIP turbine cleans surface of inner chamber walls

CIP Systems

Correct Cleaning is Essential

The very nature of dairy and food products means that the possibility of product deposits formation on the surface of the process equipment is always real. The products' fat, sugar and protein content, gives hygroscopic and sticky characteristics at the temperature and humidity conditions present during processing.

Extend your Plant Productivity

The longer the plant operates, the greater is the chance for deposit formation. Niro has successfully developed spray drying plants that minimize deposit formation and permit plant operation over longer periods of time. However, occasionally the plant has to be shut down for cleaning, and cleaning-in-place has become essential to minimize cleaning time and thereby maintain high plant productivity.

Cleaning for Individual Needs

Niro has developed systems suitable for cleaning individual items or complete process plants. This involves integrating cleaning nozzles into the plant components together with their associated pipework, and instrumentation.

Computer Controlled CIP Operations

The CIP operation is computer controlled. A programme controls pump and valve functions, and cleaning sequences are given the optimum timing for efficient cleaning of all parts of the plant. The system is flexible and different washing programmes can be selected.

Programme Flexibility

The programme software includes the flexibility to alter and adapt the washing programmes according to experience and need when new products are processed, or new operating conditions are applied. Further, individual programmes can be developed for specific products for which cleaning efficiency, cleaning time or the amount of chemicals used can differ.

Preparing the VIBRO-FLUIDIZER® for CIP cleaning by placing a tunnel which returns the cleaning liquid to the CIP kitchen



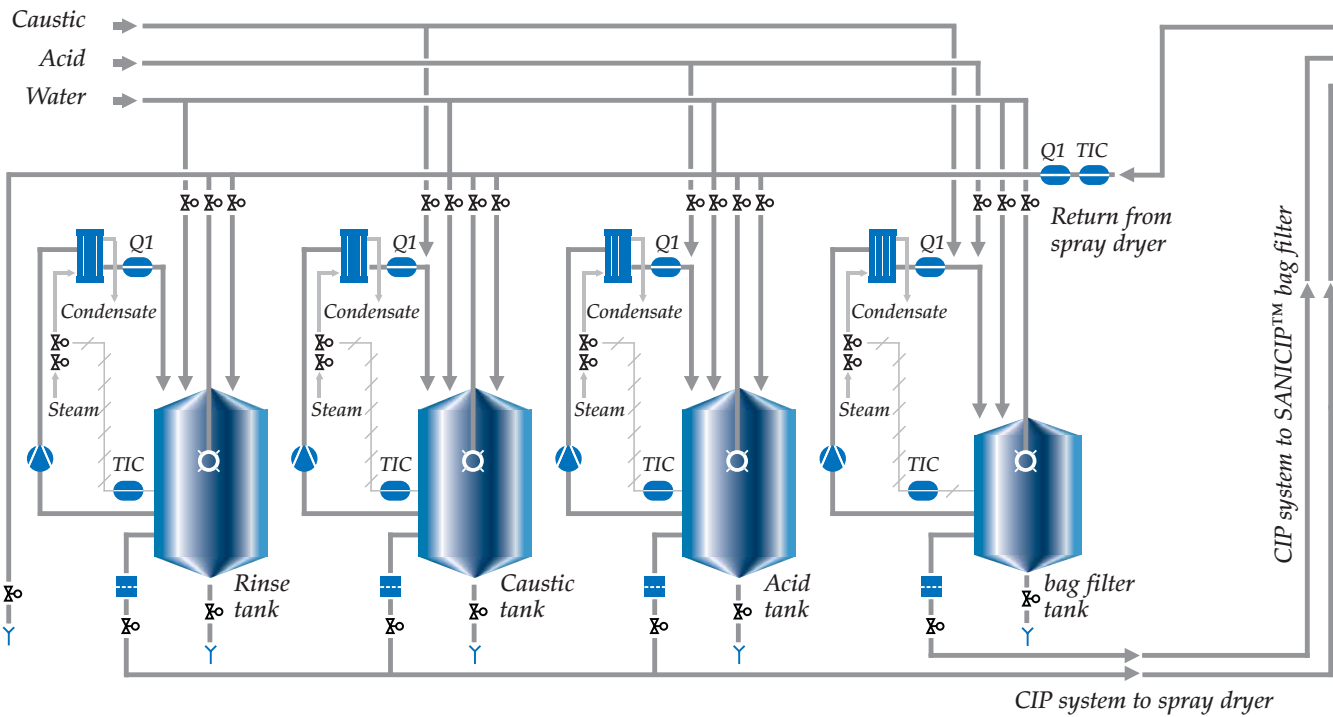

Achieving perfect product

Functionality

CIP kitchen with four tanks



CIP kitchens are designed to meet exact requirements of spray drying plants and products processed. CIP kitchens vary in the number of tanks used depending on the CIP turnaround time available.

CIP Kitchen with Four Tanks

The three-tank system, of the four-tank CIP kitchen (the fourth tank is for cleaning the bag filter), ensures a minimum of idle time when changing from one cleaning solution to another.

The CIP kitchen is designed to reuse and circulate the rinsing water and cleaning liquids, and with indirect heating of the liquids during the cleaning process. The caustic and acid concentration is measured during circulation and added automatically to achieve optimum concentration.

Features for Performance

The CIP supply line is equipped with remote operated valves and CIP supply pumps. The return line is equipped with conductivity probes and remote operated valves for

routing the caustic, acid and water to each tank or drain.

Caustic and Acid Supply

Concentrated caustic and acid are dosed into the heating circulation lines (where conductivity probes are placed) from an external source via the ring main, or alternatively from a dosing system placed next to the tanks.

CIP Kitchen with One Tank

With only one tank, each cleaning solution has to be prepared before pumping to the spray dryer. Water and cleaning liquid are dumped after each completed cleaning cycle. A one-tank system gives the lowest investment cost, but requires a longer cleaning time and increased operating costs.

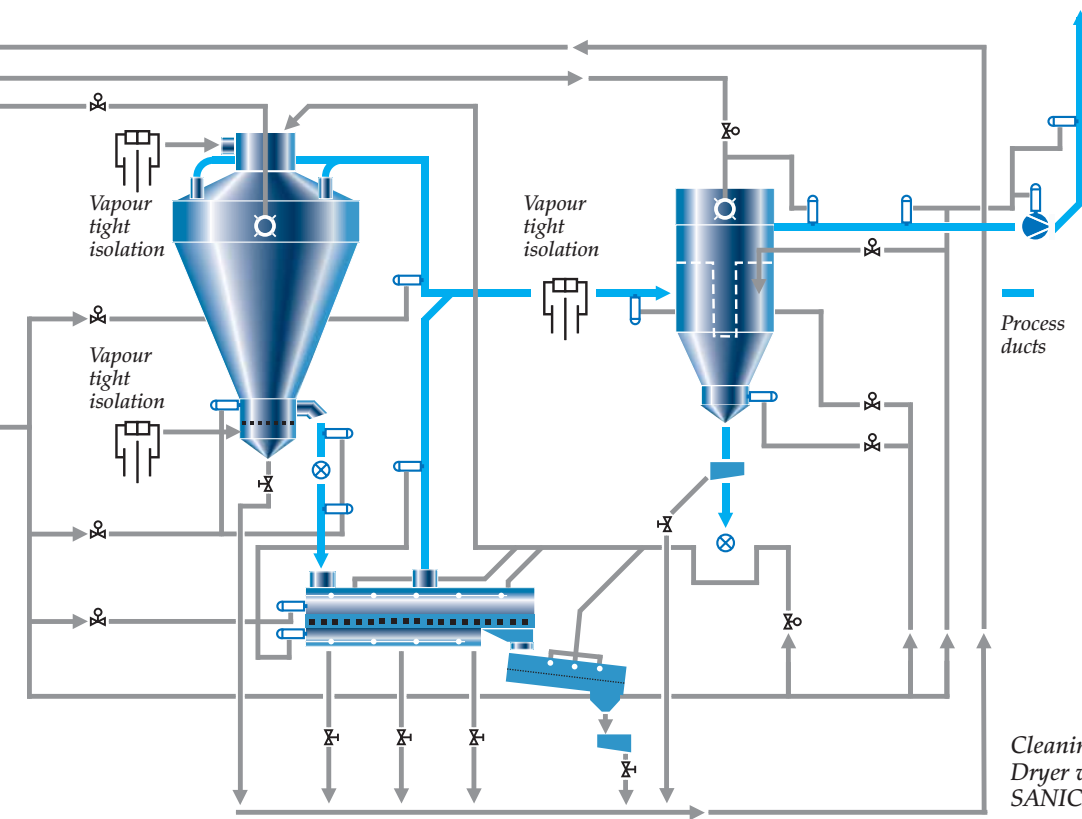

Jet liquid nozzle for cleaning of the drying chamber surface

Cleaning diagram for a Multi Stage Dryer with VIBRO-FLUIDIZER® and SANICIP™ bag filter

Operation

washing programme

Pre-Rinse

During pre-rinse, heated water is pumped from the water rinse tank to the cleaning turbine and/or to the CIP nozzles throughout the plant. The pre-rinse water goes to the drain, however due to the high concentration of residuals in the first flush this is often collected in a separate tank.

Caustic Cleaning

In the next cleaning step, a caustic solution is used. It is primarily used for cleaning where harder deposits may occur. For reuse of the caustic, a separation of product solids from the liquid may be necessary.

Intermediate Rinse

A subsequent washing step achieved by circulating water from the rinse water tank.

The intermediate rinse is recirculated and dumped after completion of the sequence.

Acid Cleaning

From the acid tank, an acid solution is recirculated for the final washing and neutralization of the caustic remaining on the surfaces of the equipment.

Final Rinse

A final clean water wash is performed as last stage of the cleaning process.

The final rinse is recirculated and dumped after completion of the sequence.

Drying out of the plant is then performed by passing warm air through the plant by activating the air heaters and fans.

The top of a SANICIP™ bag filter



The patented SANICIP™ bag filter with top cover open



Vapour tight damper isolates and keeps SANICIP™ dry during wet cleaning of other parts

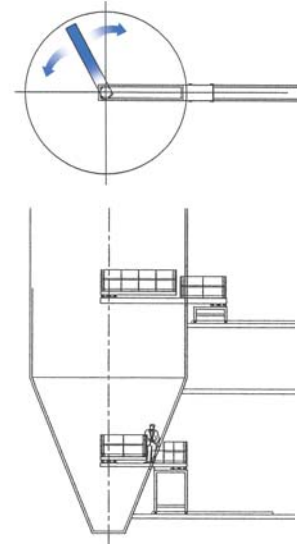

Cleaning bridge in action ready for use

Reliable

cleaning technology

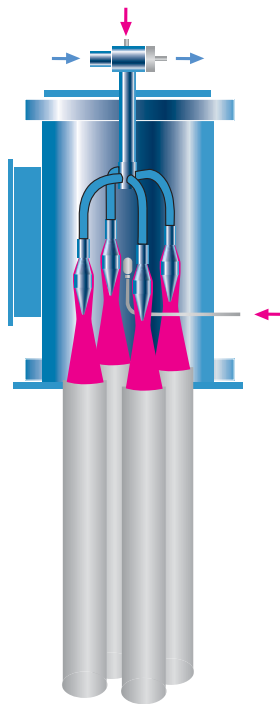

The Niro spray dryer is designed in compliance with the strictest hygiene standards and with reliable cleaning features.

SANICIP™ Bag Filter

The CIP-able bag filter has a complete, integrated CIP system, which ensures thorough cleaning of all parts:

- **The top section, where the clean air exits**
- **The filter bags**
- **The hole plate where bags are suspended**
- **The housing**

The patented cleaning process is designed for a minimum consumption of water, acid, caustic and CIP time. The special vapour tight damper

in the inlet duct to the bag filter makes it possible to wet clean either the bag filter or the rest of the plant separately and at the same time keep other parts isolated and completely dry. This reduces cleaning time, e.g. when only the chamber needs to be wet cleaned.

Special Dry Cleaning Facility

Occasionally, when a complete wet cleaning is not necessary, the operator can clean the drying chamber manually. For this purpose, Niro has designed a cleaning bridge. The bridge, which is supported on rails, is led into the chamber through an inspection door. It can be pushed and revolved, allowing the operator to sweep the entire chamber inside.

Liquid pressure operated nozzle

Pneumatically operated CIP nozzle

Activated CIP nozzle placed in duct

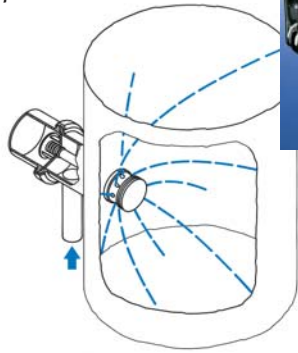

CIP nozzles installed to clean the integrated fluid bed and the spray dryer



CIP Nozzles

Liquid Pressure Operated Nozzle

The nozzle is activated by the pressure of the cleaning fluids. When not in use, the nozzle head is in a retracted position, flush with the inner surface of the equipment (spray drying chamber, cyclone, fluid bed, tanks, ducts, etc.). The nozzle causes no disturbance to the process in its retracted position, as no part protrudes to cause local turbulent conditions or to provide a ridge for deposit formation. During the CIP operation, however, the CIP liquid is pumped to the nozzle, causing the

nozzle head to move out under the effect of liquid pressure. The Teflon nozzle head now clear of the inner surface of the equipment begins to rotate and sprays liquid over the local area. Maximum coverage is achieved by the proper location of the nozzle, its capacity and operating pressure. When the cleaning operation is completed, the liquid flow to the nozzle is stopped. The nozzle head retracts to its original flush position. The nozzle can be mounted on both insulated and non-insulated equipment.

Pneumatically Operated Nozzle

The nozzle design and function is similar to that of the liquid pressure operated nozzle. However, the nozzle movement is pneumatically activated, and the nozzle design is water-tight to 10 bar. Further, pneumatically operated nozzles are very flexible as each nozzle can be controlled to open and close independently.



Process thermal heat recuperator unit and ducting equipped with CIP nozzles

Air exhaust ducting from top of spray drying chamber equipped with CIP nozzle



Cleaning-in-Place

of Spray Drying Plants

Niro is a world leader in industrial processing, with evaporation, spray drying, freeze drying, and fluid bed processing as core technologies. The Niro companies are part of the Process Engineering Division of GEA Group.



Process Engineering
Division

A company of GEA Group

Niro A/S · Gladsaxevej 305 · PO Box 45 · DK-2860 Soeborg · Denmark
Tel: +45 39 54 54 54 · Fax: +45 39 54 58 00 · food.dairy@niro.dk · www.niro.com